

# 3-6CR 90X-130X-200X

## Multi-stage centrifugal pumps



**IMPELLERS**  
Noryl FE1520PW

 Clean water

 Domestic use

 Civil use



### PERFORMANCE RANGE

- Flow rate up to **200 l/min** (12 m<sup>3</sup>/h)
- Head up to **97 m**

### APPLICATION LIMITS

- Manometric suction lift up to **7 m**
- Liquid temperature between **-10 °C** and **+40 °C**
- Ambient temperature up to **+40 °C**
- Max. working pressure **10 bar**
- Continuous service **S1**

### CONSTRUCTION AND SAFETY STANDARDS

EN 60335-1  
IEC 60335-1  
CEI 61-150

EN 60034-1  
IEC 60034-1  
CEI 2-3



### CERTIFICATIONS

Company with management system certified DNV  
ISO 9001: QUALITY



### INSTALLATION AND USE

Suitable for use with clean water and with liquids that are not chemically aggressive towards the materials from which the pump is made. As a result of their quietness these pumps are widely used in domestic applications such as the distribution of water in combination with small and medium sized pressure tanks, and for the irrigation of gardens and orchards, etc.

The pump should be installed in an enclosed environment or sheltered from inclement weather.

### PATENTS - TRADE MARKS - MODELS

- Patent n. EP14755156.8

### OPTIONS AVAILABLE ON REQUEST

- Special mechanical seal
- Other voltages or 60 Hz frequency
- IPX5 class protection

### CHARACTERISTIC CURVES AND PERFORMANCE DATA

50 Hz n= 2900 min<sup>-1</sup> HS= 0 m

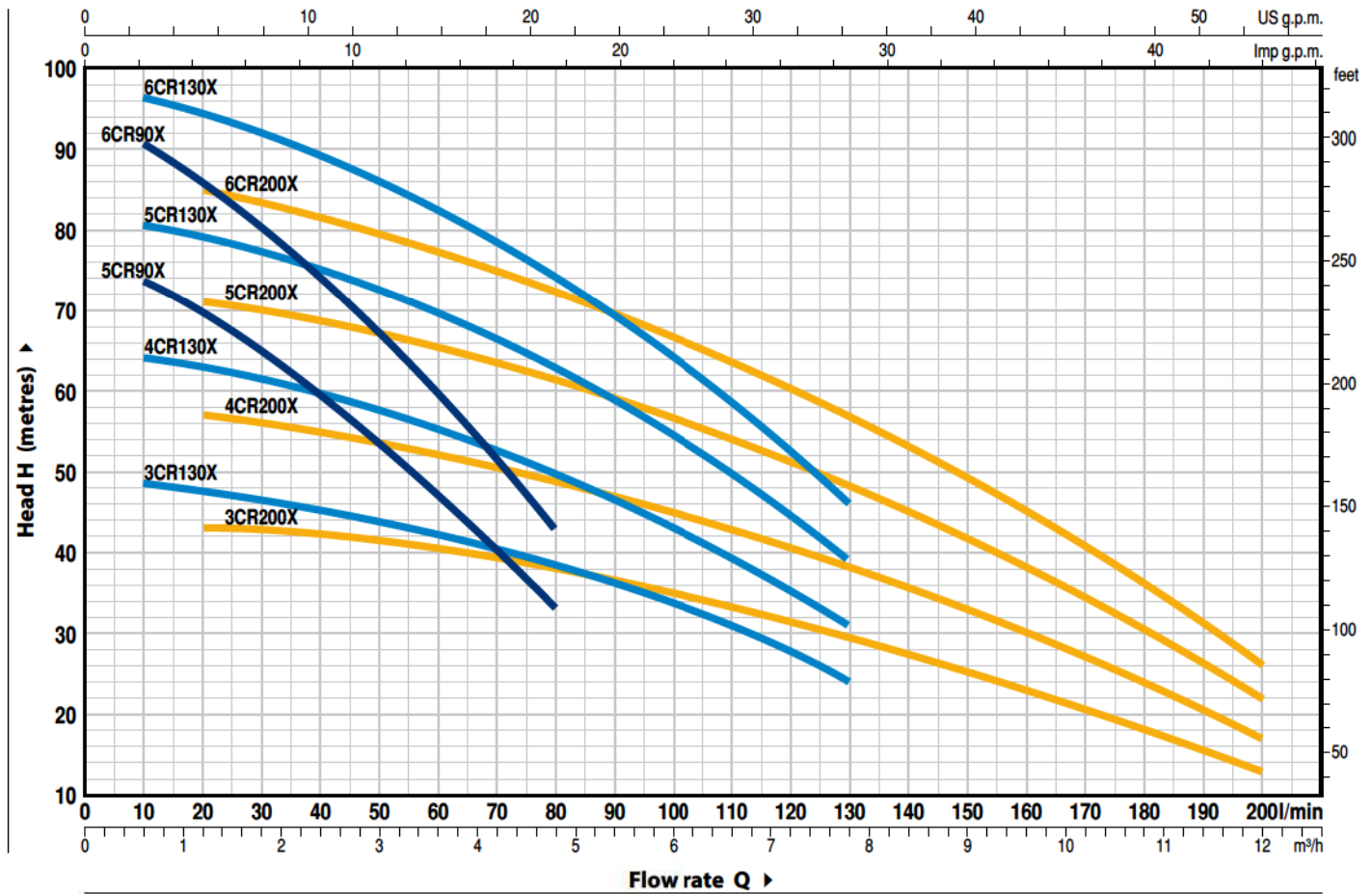

MODEL		POWER (P <sub>2</sub> )		▲	Q	Flow rate (m³/h)													
Single-phase	Three-phase	kW	HP			0	0.3	0.6	1.2	2.4	3.6	4.8	6.0	7.8	8.4	9.6	10.8	12.0	
					l/min	0	5	10	20	40	60	80	100	130	140	160	180	200	
5CRm 90X	5CR 90X	1.1	1.5	IE3	H metres	76	76	73.5	70	60.5	47	33							
6CRm 90X	6CR 90X	1.5	2			93	93	90.5	86	74.5	59.5	43							
3CRm 130X	3CR 130X	1.1	1.5			49	49	48.5	47.5	45	42.5	38.5	33.5	24					
4CRm 130X	4CR 130X	1.5	2			65	65	64	63	60	56	50	43	31					
5CRm 130X	5CR 130X	1.8	2.5			81	81	80.5	79	75	70	62.5	54	39					
-	6CR 130X	2.2	3			97	97	96.5	94.5	90	83	74.5	64	46					
3CRm 200X	3CR 200X	1.1	1.5			44	43.5	43.5	43	42	40.5	38	35	29	27.5	23	18	13	
4CRm 200X	4CR 200X	1.5	2			58	57.5	57.5	57	55	52.5	49.5	45	38	35.5	30	24	17	
5CRm 200X	5CR 200X	1.8	2.5			73	72	71.5	71	69	65.5	62	56.5	48	44.5	38	30	22	
-	6CR 200X	2.2	3			87	86	85.5	85	82	78	73	67	57	53	45	36	26	

Q = Flow rate H = Total manometric head HS = Suction height

Tolerance of characteristic curves in compliance with EN ISO 9906 Grade 3B.

▲ Performance class of the three-phase motor (IEC 60034-30-1)

# 3-6CR 90X-130X-200X

## POS. COMPONENT CONSTRUCTION CHARACTERISTICS

1	<b>PUMP BODY</b>	Stainless steel AISI 304 complete with threaded ports in compliance with ISO 228/1			
2	<b>BODY BACKPLATE</b>	Stainless steel AISI 304			
3	<b>IMPELLERS</b>	Noryl FE1520PW			
4	<b>DIFFUSERS</b>	Stainless steel AISI 304			
5	<b>MOTOR SHAFT</b>	Stainless steel EN 10088-3 - 1.4104			
6	<b>MECHANICAL SEAL</b>	<i>Seal Model</i>	<i>Shaft Diameter</i>	<i>Stationary ring</i>	<i>Materials</i> <i>Rotational ring</i> <i>Elastomer</i>
		FN-18	Ø 18 mm	Graphite	Ceramic    NBR
7	<b>BEARINGS</b>	6304 2RS - C3 / 6204 ZZ - C3E			
8	<b>CAPACITOR</b>	<i>Pump</i>	<i>Capacitance</i>		
		<i>Single-phase</i>	<i>(230 V or 240 V)</i>		
		5CRm 90X	31.5 µF - 450 VL		
		3CRm 130X			
		3CRm 200X			
		6CRm 90X	45 µF - 450 VL		
		4CRm 130X			
		4CRm 200X			
		5CRm 130X	50 µF - 450 VL		
		5CRm 200X			
9	<b>ELECTRIC MOTOR</b>	<b>3-6CRm:</b> single-phase 230 V - 50 Hz with thermal overload protector incorporated into the winding. <b>3-6CR:</b> three-phase 230/400 V - 50 Hz. <b>⇒ The three-phase pumps are fitted with high performance motors in class IE3 (IEC 60034-30-1)</b> – Insulation: class F – Protection: IP X4			

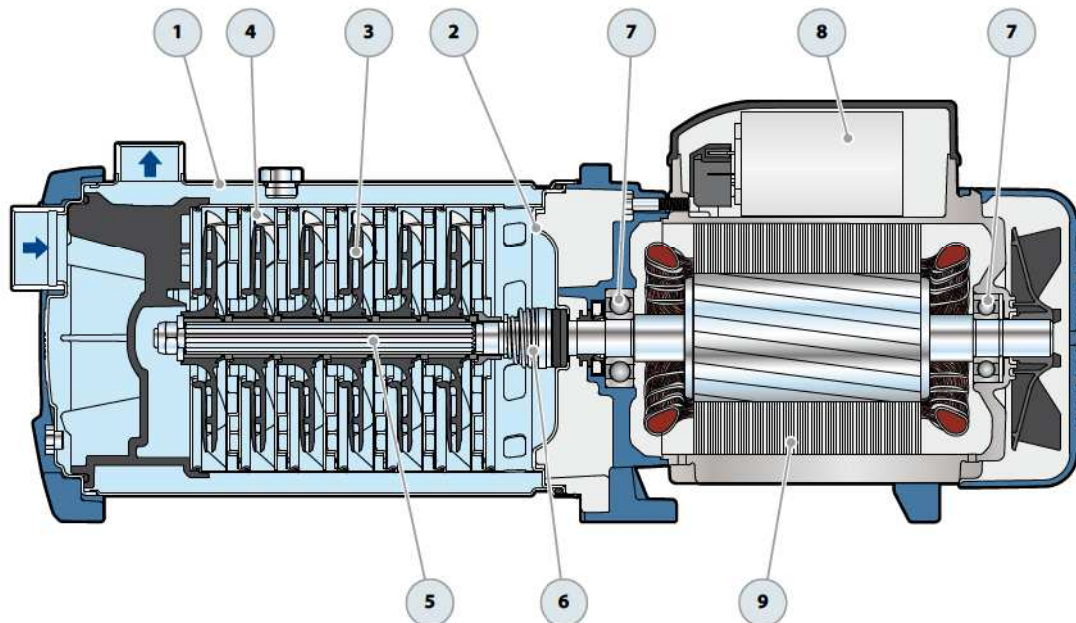

## DIMENSIONS AND WEIGHT

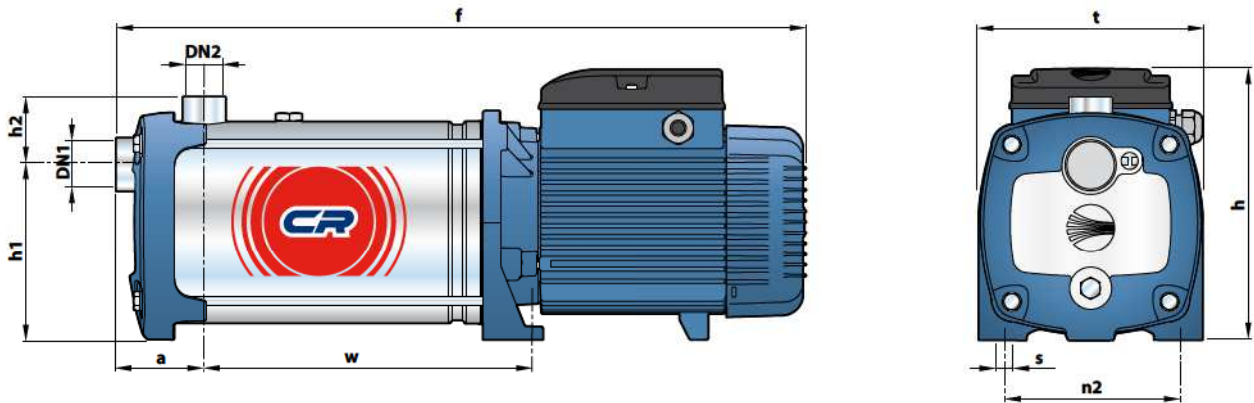

MODEL		PORTS		DIMENSIONS mm									kg	
Single-phase	Three-phase	DN1	DN2	a	f	h	h1	h2	t	n2	w	s	1~	3~
5CRm 90X	5CR 90X	1 1/4"	1"	73	549	228	145	56	185	145	245	11	19.4	19.4
6CRm 90X	6CR 90X				575						271		21.7	21.7
3CRm 130X	3CR 130X				497						193		18.0	18.0
4CRm 130X	4CR 130X				523						219		19.9	19.9
5CRm 130X	5CR 130X				569						245		-	23.3
-	6CR 130X				595						271		-	24.0
3CRm 200X	3CR 200X				497						193		18.0	18.0
4CRm 200X	4CR 200X				523						219		19.9	19.9
5CRm 200X	5CR 200X				569						245		-	23.3
-	6CR 200X				595						271		-	24.0

## ABSORPTION

MODEL	VOLTAGE	
	230 V	240 V
Single-phase	230 V	240 V
5CRm 90X	9.3 A	9.0 A
6CRm 90X	11.0 A	10.8 A
3CRm 130X	8.5 A	8.3 A
4CRm 130X	10.3 A	9.9 A
5CRm 130X	12.5 A	12.0 A
3CRm 200X	8.7 A	8.0 A
4CRm 200X	10.5 A	10.1 A
5CRm 200X	12.5 A	12.0 A

MODEL	VOLTAGE					
	230 V	400 V	690 V	240 V	415 V	720 V
Three-phase	230 V	400 V	690 V	240 V	415 V	720 V
5CR 90X	6.1 A	3.5 A	2.0 A	5.5 A	3.2 A	1.8 A
6CR 90X	7.3 A	4.2 A	2.5 A	7.8 A	4.5 A	2.6 A
3CR 130X	5.6 A	3.2 A	1.9 A	5.5 A	3.2 A	1.8 A
4CR 130X	6.9 A	4.0 A	2.3 A	8.1 A	4.7 A	2.7 A
5CR 130X	9.0 A	5.2 A	3.0 A	9.0 A	5.2 A	3.0 A
6CR 130X	9.9 A	5.7 A	3.3 A	9.5 A	5.5 A	3.2 A
3CR 200X	5.9 A	3.4 A	1.9 A	5.5 A	3.2 A	1.8 A
4CR 200X	7.3 A	4.2 A	2.5 A	7.0 A	4.0 A	2.3 A
5CR 200X	9.4 A	5.4 A	3.2 A	8.3 A	4.8 A	2.8 A
6CR 200X	10.2 A	5.9 A	3.5 A	9.8 A	5.7 A	3.3 A