

# 3-7CR 90-130-200

## Multi-stage centrifugal pumps



### IMPELLERS

Stainless steel AISI 304

 Clean water

 Domestic use

 Civil use



### PERFORMANCE RANGE

- Flow rate up to **200 l/min** (12 m<sup>3</sup>/h)
- Head up to **111 m**

### APPLICATION LIMITS

- Manometric suction lift up to **7 m**
- Liquid temperature between **-10 °C** and **+90 °C**
- Ambient temperature up to **+40 °C**
- Max. working pressure **10 bar**
- Continuous service **S1**

### CONSTRUCTION AND SAFETY STANDARDS

EN 60335-1  
IEC 60335-1  
CEI 61-150

EN 60034-1  
IEC 60034-1  
CEI 2-3



### CERTIFICATIONS

Company with management system certified DNV  
ISO 9001: QUALITY



### INSTALLATION AND USE

Suitable for use with clean water and with liquids that are not chemically aggressive towards the materials from which the pump is made. As a result of their quietness these pumps are widely used in domestic applications such as the distribution of water in combination with small and medium sized pressure tanks, and for the irrigation of gardens and orchards, etc. The pump should be installed in an enclosed environment or sheltered from inclement weather.

### PATENTS - TRADE MARKS - MODELS

- Patent n. EP14755156.8

### OPTIONS AVAILABLE ON REQUEST

- Special mechanical seal
- Other voltages or 60 Hz frequency
- IPX5 class protection

### CHARACTERISTIC CURVES AND PERFORMANCE DATA

50 Hz n= 2900 min<sup>-1</sup> HS= 0 m

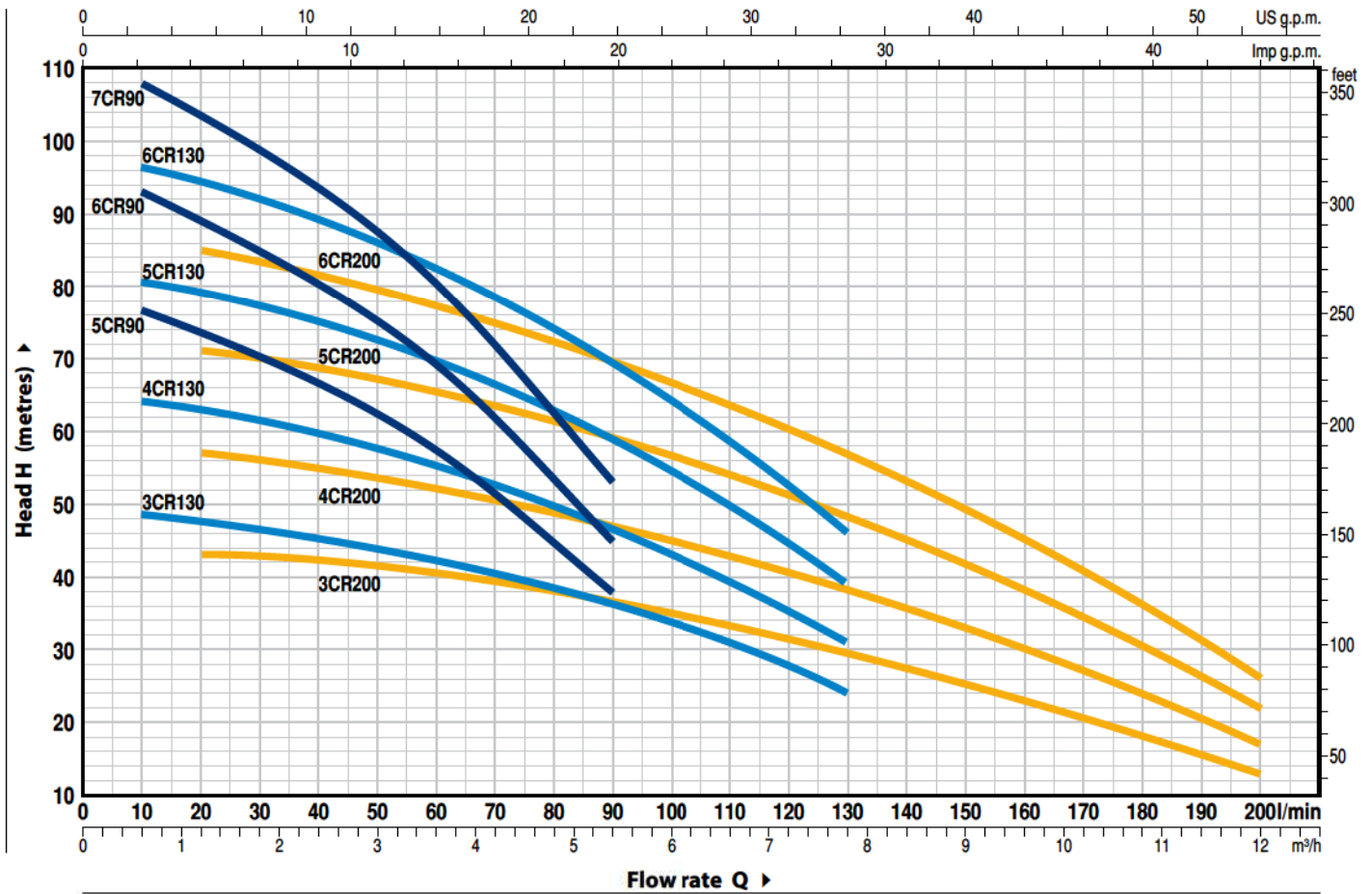

MODEL		POWER (P <sub>2</sub> )		▲	Q	Flow rate (m³/h)															
Single-phase	Three-phase	kW	HP			0	0.3	0.6	1.2	2.4	3.6	4.8	5.4	6.0	7.8	8.4	9.6	10.8	12.0		
						0	5	10	20	40	60	80	90	100	130	140	160	180	200		
5CRm 90	5CR 90	1.1	1.5	IE3	H metres	80	78	77	74	67	57	45	38								
6CRm 90	6CR 90	1.5	2			96	94	92	88	80	69	53	45								
7CRm 90	7CR 90	1.8	2.5			111	110	108	103	93	80	63	53								
3CRm 130	3CR 130	1.1	1.5			49	49	48.5	47.5	45	42.5	38.5	36	33.5	24						
4CRm 130	4CR 130	1.5	2			65	65	64	63	60	56	50	47	43	31						
5CRm 130	5CR 130	1.8	2.5			81	81	80.5	79	75	70	62.5	59	54	39						
-	6CR 130	2.2	3			97	97	96.5	94.5	90	83	74.5	69	64	46						
3CRm 200	3CR 200	1.1	1.5			44	43.5	43.5	43	42	40.5	38	36.5	35	29	27.5	23	18	13		
4CRm 200	4CR 200	1.5	2			58	57.5	57.5	57	55	52.5	49.5	47	45	38	35.5	30	24	17		
5CRm 200	5CR 200	1.8	2.5			73	72	71.5	71	69	65.5	62	59	56.5	48	44.5	38	30	22		
-	6CR 200	2.2	3			87	86	85.5	85	82	78	73	69	67	57	53	45	36	26		

Q = Flow rate H = Total manometric head HS = Suction height

Tolerance of characteristic curves in compliance with EN ISO 9906 Grade 3B.

▲ Performance class of the three-phase motor (IEC 60034-30-1)

# 3-7CR 90-130-200

## POS. COMPONENT CONSTRUCTION CHARACTERISTICS

1	<b>PUMP BODY</b>	Stainless steel AISI 304 complete with threaded ports in compliance with ISO 228/1				
2	<b>BODY BACKPLATE</b>	Stainless steel AISI 304				
3	<b>IMPELLERS</b>	Stainless steel AISI 304				
4	<b>DIFFUSERS</b>	Stainless steel AISI 304				
5	<b>MOTOR SHAFT</b>	Stainless steel AISI 431				
6	<b>MECHANICAL SEAL</b>	<i>Seal</i>	<i>Shaft</i>	<i>Materials</i>		
		<i>Model</i>	<i>Diameter</i>	<i>Stationary ring</i>	<i>Rotational ring</i>	<i>Elastomer</i>
		FN-18	Ø 18 mm	Graphite	Silicon carbide	EPDM
7	<b>BEARINGS</b>	<b>6304 2RS - C3 / 6204 ZZ - C3E</b>				
8	<b>CAPACITOR</b>	<i>Pump</i>	<i>Capacitance</i>			
		<i>Single-phase</i>	<i>(230 V or 240 V)</i>			
		5CRm 90				
		3CRm 130	31.5 µF - 450 VL			
		3CRm 200				
		6CRm 90				
		4CRm 130	45 µF - 450 VL			
		4CRm 200				
		7CRm 90				
		5CRm 130	50 µF - 450 VL			
5CRm 200						
9	<b>ELECTRIC MOTOR</b>	<b>3-7CRm:</b> single-phase 230 V - 50 Hz with thermal overload protector incorporated into the winding.				
		<b>3-7CR:</b> three-phase 230/400 V - 50 Hz.				
		⇒ <b>The three-phase pumps are fitted with high performance motors in class IE3 (IEC 60034-30-1)</b>				
		- Insulation: class F - Protection: IP X4				

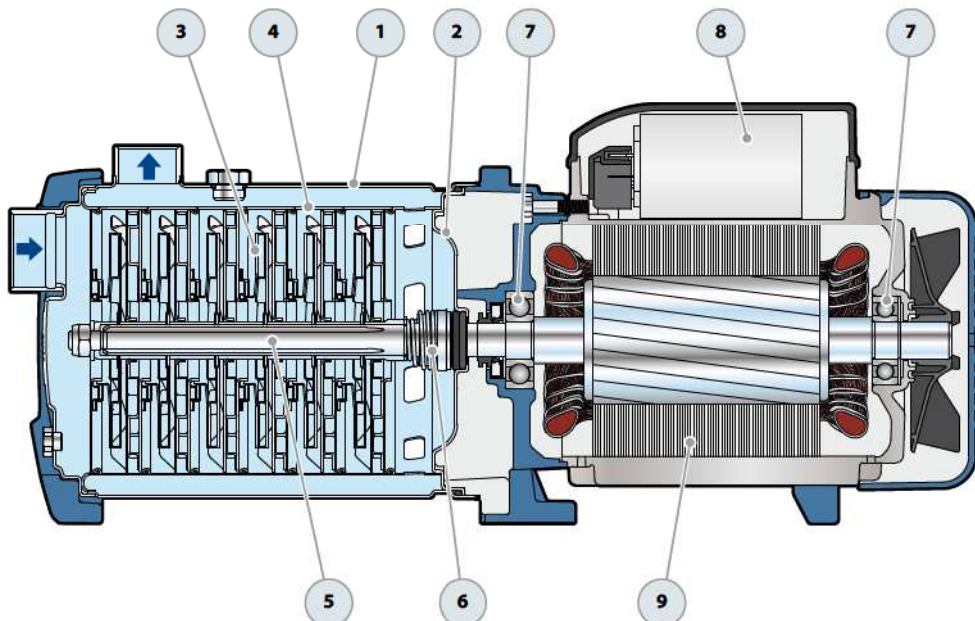

## DIMENSIONS AND WEIGHT

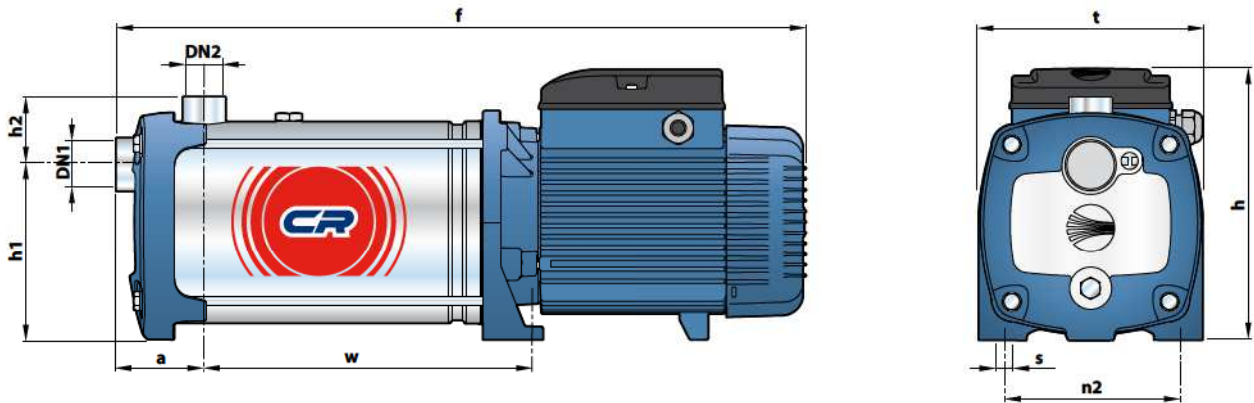

MODEL		PORTS		DIMENSIONS mm									kg	
Single-phase	Three-phase	DN1	DN2	a	f	h	h1	h2	t	n2	w	s	1~	3~
5CRm 90	5CR 90	1 1/4"	1"	73	497	228	145	56	185	145	193	11	20.2	20.2
6CRm 90	6CR 90				523						219		22.0	22.0
7CRm 90	7CR 90				569						245		26.0	26.0
3CRm 130	3CR 130				445						141		18.5	18.5
4CRm 130	4CR 130				471						167		20.4	20.4
5CRm 130	5CR 130				517						193		23.7	23.7
-	6CR 130				543						219		-	24.8
3CRm 200	3CR 200				445						141		18.5	18.5
4CRm 200	4CR 200				471						167		20.4	20.4
5CRm 200	5CR 200				517						193		23.7	23.7
-	6CR 200	543	219	-	24.8									

## ABSORPTION

MODEL	VOLTAGE	
	230 V	240 V
Single-phase	230 V	240 V
5CRm 90	9.0 A	8.6 A
6CRm 90	10.5 A	10.1 A
7CRm 90	12.5 A	12.0 A
3CRm 130	8.5 A	8.1 A
4CRm 130	10.3 A	9.9 A
5CRm 130	12.5 A	12.0 A
3CRm 200	8.7 A	8.3 A
4CRm 200	10.5 A	10.1 A
5CRm 200	12.5 A	12.0 A

MODEL	VOLTAGE					
	230 V	400 V	690 V	240 V	415 V	720 V
Three-phase	230 V	400 V	690 V	240 V	415 V	720 V
5CR 90	6.1 A	3.5 A	2.0 A	5.9 A	3.4 A	1.9 A
6CR 90	6.9 A	4.0 A	2.3 A	6.6 A	3.8 A	2.2 A
7CR 90	8.3 A	4.8 A	2.8 A	8.0 A	4.6 A	2.7 A
3CR 130	5.6 A	3.2 A	1.8 A	5.4 A	3.1 A	1.8 A
4CR 130	6.9 A	4.0 A	2.3 A	6.6 A	3.8 A	2.2 A
5CR 130	8.7 A	5.0 A	2.9 A	8.3 A	4.8 A	2.8 A
6CR 130	9.0 A	5.2 A	3.0 A	8.6 A	5.0 A	2.9 A
3CR 200	5.9 A	3.4 A	2.0 A	5.7 A	3.3 A	1.9 A
4CR 200	7.3 A	4.2 A	2.4 A	6.9 A	4.0 A	2.3 A
5CR 200	8.7 A	5.0 A	2.9 A	8.3 A	4.8 A	2.8 A
6CR 200	9.5 A	5.5 A	3.2 A	9.2 A	5.3 A	3.0 A