

PQ 81-Bs

INDUSTRIAL USE

Pumps with peripheral impeller



Pump body in **BRASS**

The PQ-BS electric pump is supplied fully painted



PERFORMANCE RANGE

- Flow rate up to **20 l/min** (1.2 m³/h)
- Head up to **95 m**

APPLICATION LIMITS

- Manometric suction lift up to **8 m**
- Liquid temperature between **-10 °C** and **+90 °C**
- Ambient temperature between **-10 °C** and **+40 °C**
- Max. working pressure **10 bar**
- Continuous service **S1**

CONSTRUCTION AND SAFETY STANDARDS

EN 60335-1
IEC 60335-1
CEI 61-150

EN 60034-1
IEC 60034-1
CEI 2-3



CERTIFICATIONS

Company with management system certified DNV ISO 9001: QUALITY



INSTALLATION AND USE

Suitable for use with clean water that does not contain abrasive particles and with liquids that are not chemically aggressive towards the materials from which the pump is made.

The hydraulic characteristics of these pump, coupled with their compactness, makes them suitable for use in industrial applications. Installation needs to be undertaken in well ventilated closed areas or anyway protected from bad weather.

PATENTS - TRADE MARKS - MODELS

- Motor bracket n° IT1243605
- Registered model

OPTIONS AVAILABLE ON REQUEST

- Special mechanical seal
- EN 10088-3 - 1.4401 (AISI 316) stainless steel pump shaft
- Other voltages or 60 Hz frequency
- IP X5 protection

CHARACTERISTIC CURVES AND PERFORMANCE DATA

50 Hz n= 2900 min⁻¹ HS= 0 m

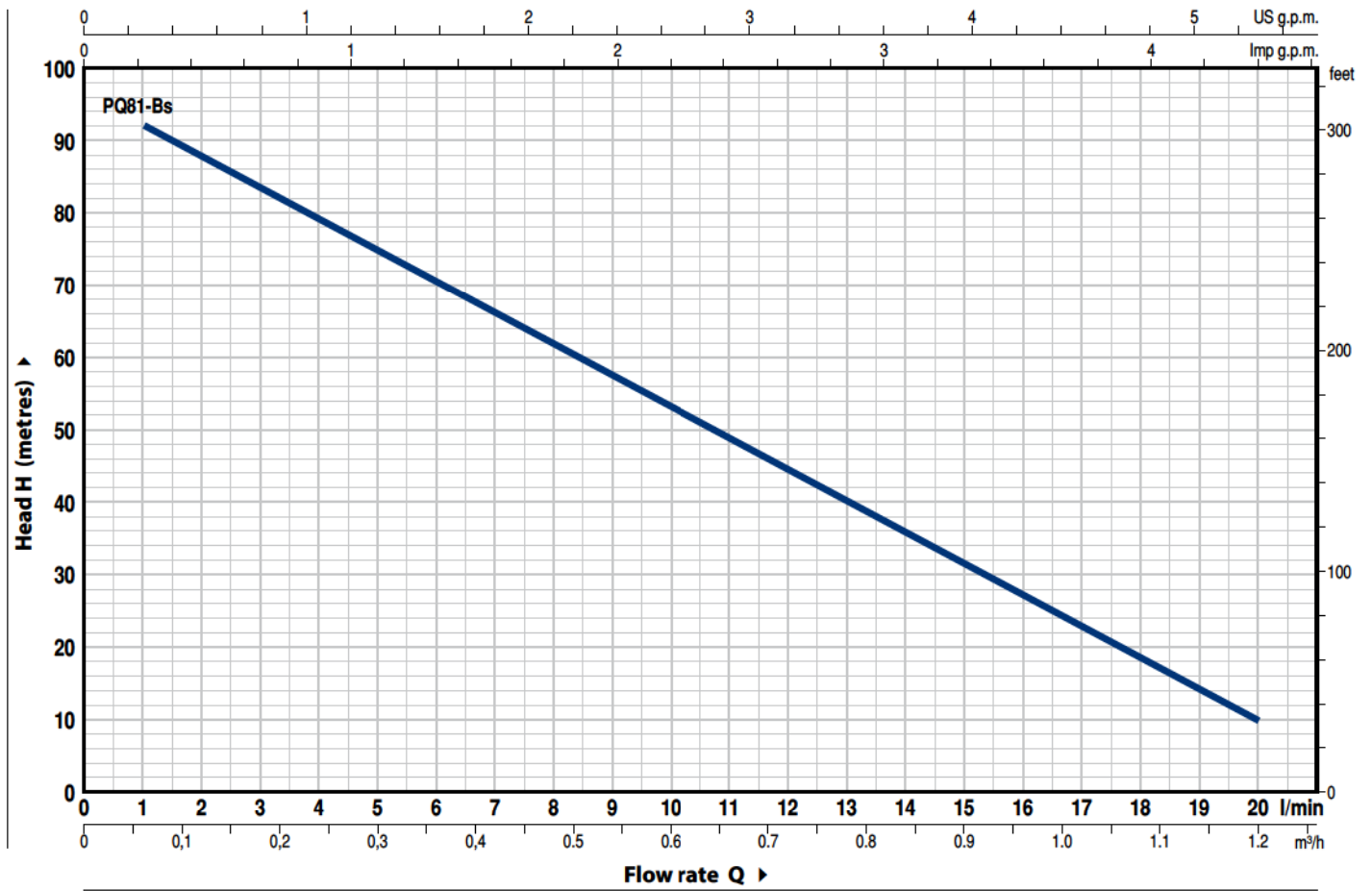

| MODEL | | POWER (P ₂) | | | Q | Flow rate | | | | | | | | | | | | | | | |
|--------------|-------------|-------------------------|------|-----|----------|-------------------|----|------|------|------|------|------|------|------|------|------|------|-----|--|--|--|
| Single-phase | Three-phase | kW | HP | ▲ | | m ³ /h | 0 | 0.06 | 0.12 | 0.24 | 0.36 | 0.48 | 0.60 | 0.72 | 0.84 | 0.96 | 1.08 | 1.2 | | | |
| | | | | | l/min | 0 | 1 | 2 | 4 | 6 | 8 | 10 | 12 | 14 | 16 | 18 | 20 | | | | |
| PQm 81-Bs | PQ 81-Bs | 0.55 | 0.75 | IE3 | H metres | 95 | 92 | 87.5 | 79 | 70.5 | 62 | 53 | 44.5 | 36 | 27.5 | 18.5 | 10 | | | | |

Q = Flow rate H = Total manometric head HS = Suction height

Tolerance of characteristic curves in compliance with EN ISO 9906 Grade 3B.

▲ Three-phase motor efficiency class (IEC 60034-30-1)

PQ 81-Bs

| POS. | COMPONENT | CONSTRUCTION CHARACTERISTICS | | | | |
|------|------------------------|---|-----------------------|------------------------|----------------------------------|------------------|
| 1 | PUMP BODY | Brass complete with threaded ports in compliance with ISO 228/1 | | | | |
| 2 | MOTOR BRACKET | Aluminium with brass insert (patented), reduces the risk of impeller seizure | | | | |
| 3 | IMPELLER | Brass with peripheral radial vanes | | | | |
| 4 | MOTOR SHAFT | Stainless steel AISI 431 | | | | |
| 5 | MECHANICAL SEAL | <i>Seal Model</i> | <i>Shaft Diameter</i> | <i>Stationary ring</i> | <i>Materials Rotational ring</i> | <i>Elastomer</i> |
| | | ST1-12 | Ø 12 mm | Silicon carbide | Graphite | NBR |
| 6 | BEARINGS | 6201 ZZ / 6201 ZZ | | | | |
| 7 | ELECTRIC MOTOR | <p>PQm-Bs: single-phase 230 V - 50 Hz with thermal overload protector incorporated into the winding. PQ-Bs: three-phase 230/400 V - 50 Hz.</p> <p>⇒ The pump is fitted with a high performance motor in class IE3 (IEC 60034-30-1)</p> <ul style="list-style-type: none"> - Insulation: class F - Protection: IP X4 | | | | |

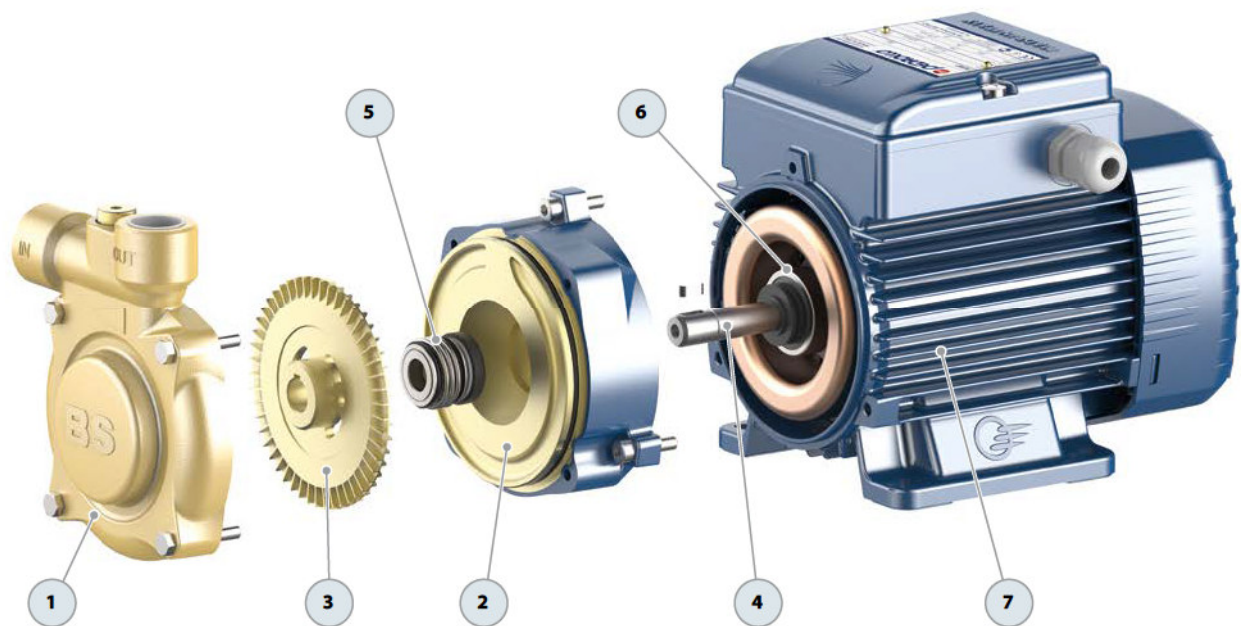

DIMENSIONS AND WEIGHT

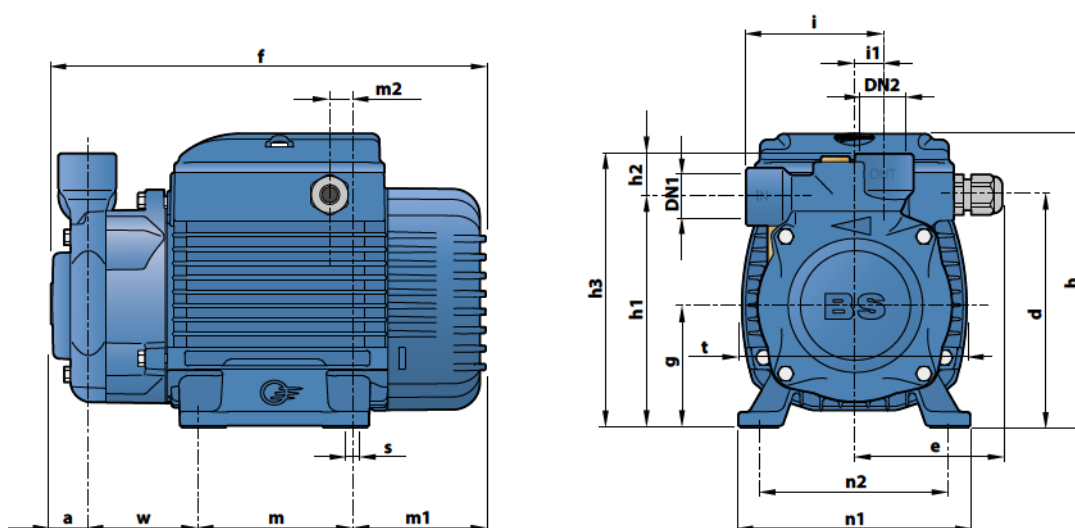

| MODEL | | PORTS | | DIMENSIONS mm | | | | | | | | | | | | | | | | | kg | | | |
|--------------|-------------|-------|-----|---------------|-------|------|-----|----|-----|-----|----|-----|----|----|----|----|-----|-----|-----|-----|----|---|-----|-----|
| Single-phase | Three-phase | DN1 | DN2 | a | d | e | f | g | h | h1 | h2 | h3 | i | i1 | m | m1 | m2 | n1 | n2 | t | w | s | 1~ | 3~ |
| PQm 81-Bs | PQ 81-Bs | ½" | ½" | 18 | 119.5 | 76.5 | 223 | 63 | 153 | 119 | 22 | 141 | 71 | 15 | 80 | 69 | 8.5 | 120 | 100 | 117 | 55 | 7 | 7.0 | 7.0 |

ABSORPTION

| MODEL | VOLTAGE |
|--------------|---------|
| Single-phase | 230 V |
| PQm 81-Bs | 3.5 A |

| MODEL | VOLTAGE | |
|-------------|---------|-------|
| Three-phase | 230 V | 400 V |
| PQ 81-Bs | 2.4 A | 1.4 A |

CAPACITORS

| MODEL | CAPACITANCE |
|--------------|-----------------|
| Single-phase | (230 V o 240 V) |
| PQm 81-Bs | 14 µF - 450 VL |